

EXTRAL
ALUMINIUM

**KATALOG PROFILI
STANDARDOWYCH**

CATALOGUE
OF **STANDARD PROFILES**

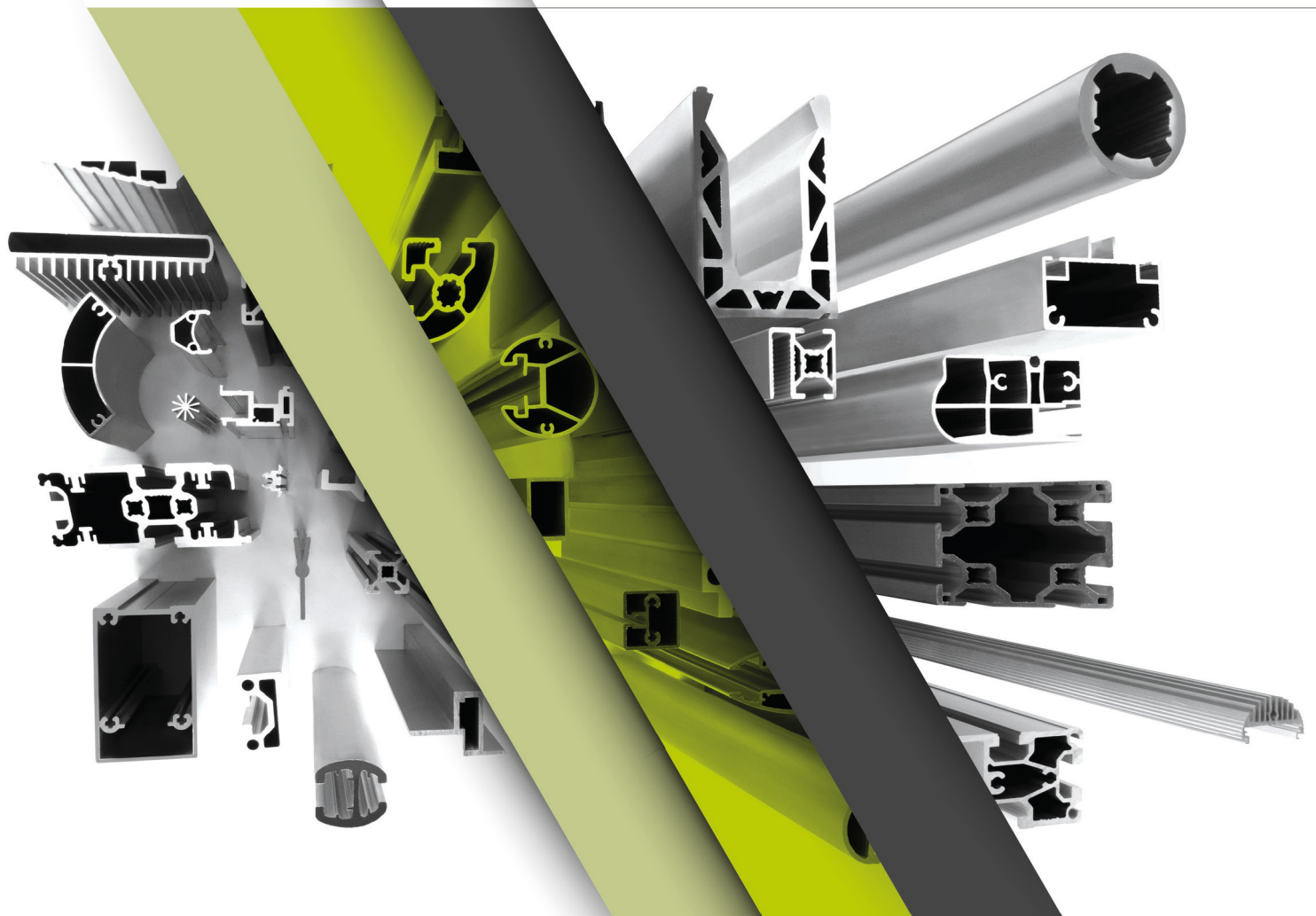

EDYCJA EDITION 01.2025

PROFILE STANDARDOWE

KĄTOWNIKI NIERÓWNORAMIENNE									
NON EQUAL L-SHAPES / UNGLEICHSCHENLIGE L-PROFILE									
NUMER PROFILU Profile no. Profilnr.	WYMIARY [mm] Dimensions [mm] / Abmessungen [mm]						MASA [g/m] Weight [g/m] Gewicht [g/m]	OBWÓD [mm] Perimeter [mm] Perimeter [mm]	
	A	B	G	g	R	r			
S1112	20	15	2	2	0,2	0,2	178	69,48	
S1086	30	15	2	2	0,2	0,2	232	89,48	
S1040	30	20	2	2	0,3	0,3	259	99,22	
S1149	35	20	3	3	0,2	0,2	421	109,48	
S1585	40	20	1,5	1,5	0,2	0,2	237	119,57	
S1041	40	20	2	2	0,3	0,3	313	119,22	
S1148	40	25	3	3	0,2	0,2	502	129,4	
S1243	40	30	3	3	0,3	0,2	542	139,36	
S1495	40	30	4	4	0,3	0,2	713	139,36	
S1277	40	30	5	5	0,3	0,2	877	139,36	
S1296	50	20	2	2	0,3	0,2	367	139,36	
S1042	50	25	2	2	0,3	0,3	394	149,22	
S1308	50	30	3	3	0,3	0,2	623	159,36	
S1323	50	30	5	5	0,5	0,2	1112	158,92	
S1119	50	40	3	3	0,3	0,3	704	179,27	
S1578	60	20	1,3	1,3	0,3	0,2	276	159,27	
S1043	60	20	2	2	0,3	0,3	421	159,22	
S1175	60	30	7	7	0,4	0,2	1568	179,06	
S1355	60	40	2	2	0,2	0,2	529	199,57	
S1160	60	40	3	3	0,2	0,2	786	199,48	
S1196	60	40	5	5	0,4	0,2	1282	199,05	
S1482	60	45	1,8	1,8	0,2	1,0	502	209,14	
S1120	60	50	3	3	0,3	0,3	866	219,27	
S1254	70	20	2	2	0,3	0,3	475	179,36	
S1273	70	50	1,5	1,5	0,2	0,2	480	239,57	
S1507	70	50	2	2	0,2	0,2	637	239,57	
S1044	80	20	2	2	0,3	0,3	529	199,22	
S1121	80	50	3	3	0,3	0,3	1028	259,27	
S1587	80	60	2	2	0,2	0,2	745	279,57	
S1480	85	25	4	4	0,3	0,2	1145	219,36	
S1174	100	30	3	3	0,3	0,2	1028	259,27	
S1122	100	50	3	3	0,3	0,3	1190	299,72	
S1123	120	50	3	3	0,3	0,3	1352	339,27	
S1124	140	50	3	3	0,3	0,3	1514	379,27	
S1146	150	40	2	2	0,2	0,2	1015	379,57	
S1131	160	50	3	3	0,4	0,2	1676	419,05	
S1125	180	50	3	3	0,3	0,2	1838	459,27	
S1141	200	50	3	3	0,3	0,2	2000	499,27	
S1152	220	50	3	3	0,3	0,2	2162	539,27	

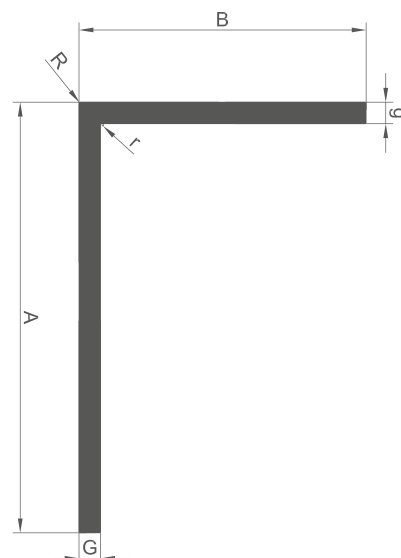

KĄTOWNIKI RÓWNORAMIENNE									
EQUAL L-SHAPES / GLEICHSCHENLIGE L-PROFILE									
NUMER PROFILU Profile no. Profilnr.	WYMIARY [mm] Dimensions [mm] / Abmessungen [mm]					MASA [g/m] Weight [g/m] Gewicht [g/m]	OBWÓD [mm] Perimeter [mm] Perimeter [mm]		
	A	G	g	R	r				
S1155	15	2	2	0,2	0,2	151	59,48		
S1032	20	2	2	0,3	0,3	205	79,23		
S1033	25	2	2	0,3	0,3	259	99,93		
S1132	25	3	3	0,5	0,2	380	99,01		
S1034	30	2	2	0,4	0,4	313	118,97		
S1182	30	3	3	0,3	0,3	461	119,23		
S1035	35	2	2	0,3	0,3	367	139,22		
S1036	35	3	3	0,3	0,3	542	139,22		
S1350	35	4	4	0,3	0,2	713	139,36		
S1037	40	2	2	0,3	0,3	421	159,23		
S1038	40	3	3	0,3	0,3	623	159,22		
S1134	40	4	4	0,5	0,5	802	158,71		
S1039	50	2	2	0,3	0,3	530	199,23		
S1113	50	3	3	0,2	0,2	786	199,48		
S1303	50	4	4	0,2	0,2	1037	199,57		
S1202	50	5	5	0,4	0,2	1282	199,05		
S1337	60	3	3	0,2	0,2	948	239,57		

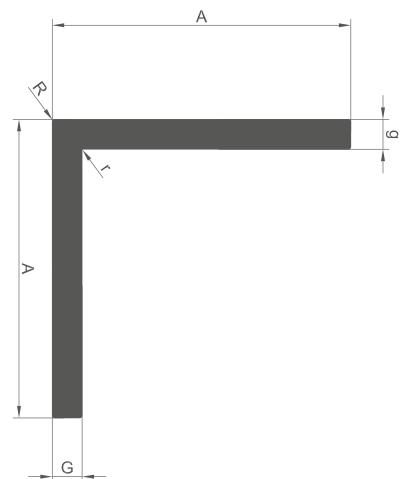

TEOWNIKI

T SHAPES / T-PROFILE

NUMER PROFILU Profile no. Profilnr.	WYMIARY [mm] Dimensions [mm] / Abmessungen [mm]						MASA [g/m] Weight [g/m] Gewicht [g/m]	OBWÓD [mm] Perimeter [mm] Perimeter [mm]
	A	B	G	g	R	r		
S1569	20	10	2	2	0,2	0,2	151	59,48
S1045	20	20	2	2	0,3	0,3	205	78,97
S1046	30	30	2	2	0,3	0,3	313	118,97
S1115	60	50	2	2	0,3	0,3	583	219,05
S1344	65	50	2	2	0,2	0,2	610	229,49
S1171	80	50	2	2	0,2	0,2	691	259,31
S1216	90	45	2	2	0,2	0,2	718	269,31
S1047	100	50	2	2	0,3	0,3	799	298,97
S1506	100	150	3	5	0,5	0,2	2794	498,71
S1214	110	45	2	2	0,2	0,2	826	309,48
S1116	110	50	2	2	0,3	0,3	853	319,90
S1117	120	50	2	2	0,3	0,3	907	339,05
S1588	120	60	2	2	0,2	0,2	961	359,49
S1188	120	60	5	5	0,4	0,2	2362	358,80
S1272	120	70	2	2	0,2	0,2	1015	379,49
S1170	140	50	2	2	0,2	0,2	1015	379,31

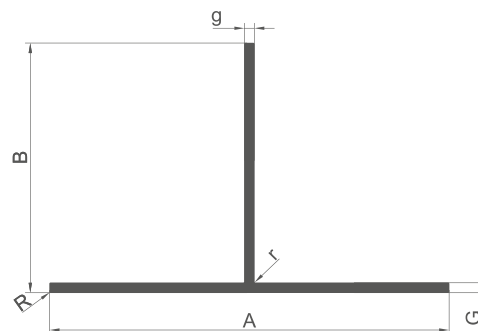

CEOWNIKI

U SHAPES / U-PROFILE

NUMER PROFILU Profile no. Profilnr.	WYMIARY [mm] Dimensions [mm] / Abmessungen [mm]						MASA [g/m] Weight [g/m] Gewicht [g/m]	OBWÓD [mm] Perimeter [mm] Perimeter [mm]
	A	B	G	g	R	r		
S1027	12	12	2	2	0,3	0,3	173	66,97
S1028	15	15	2	2	0,3	0,3	221	84,97
S1084	15	30	1,5	1,5	0,2	0,2	292	146,31
S1029	20	10	2	2	0,3	0,3	194	74,97
S1522	20	20	1,5	1,5	0,2	0,2	231	116,49
S1082	20	20	2	2	0,2	0,2	302	115,31
S1302	20	30	2	2	0,2	0,2	410	155,49
S1361	20	40	2	2	0,2	0,2	518	195,49
S1485	22	22	2	2	0,2	0,2	335	127,49
S1083	25	25	2	2	0,2	0,2	383	145,31
S1110	25	25	3	3	0,3	0,3	559	143,05
S1030	30	15	2	2	0,3	0,3	302	114,97
S1222	30	20	2	2	0,2	0,2	356	135,48
S1085	30	23	1,7	1,7	0,2	0,2	333	147,91
S1476	35	35	2	2	0,2	0,2	545	205,48
S1234	40	20	2	2	0,2	0,2	410	155,48
S1097	40	60	2	2	0,2	0,2	842	315,31
S1351	45	20	1,5	1,5	0,2	0,2	332	166,31
S1523	50	30	3	3	0,3	0,3	842	213,23
S1267	50	45	2	2	0,2	0,2	734	275,49
S1521	50	50	3	3	0,3	0,3	1166	293,23
S1181	50	50	4	4	0,2	0,2	1533	290,97
S1441	60	20	2	2	0,3	0,3	518	195,23
S1368	60	30	3	3	0,2	0,2	923	233,48
S1031	60	40	2,5	2,5	0,3	0,3	911	273,97
S1111	70	25	3	3	0,3	0,3	923	233,05
S1576	100	50	8	8	0,5	0,3	3974	282,46

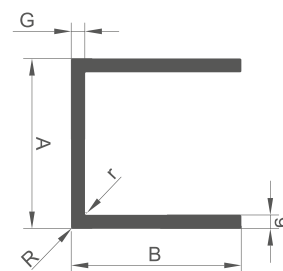

PRĘTY KWADRATOWE				
SQUARE BARS / QUADRATISCHE STANGEN				
NUMER PROFILU Profile no. Profilnr.	WYMIARY [mm] Dimensions [mm] / Abmessungen [mm]		MASA [g/m] Weight [g/m] Gewicht [g/m]	OBWÓD [mm] Perimeter [mm] Perimeter [mm]
	A	R		
S1255	25	1	1685	98,28
S1475	50	1	6748	198,28
S1479	53	1	7582	210,28
S1572	80	1	17278	318,22

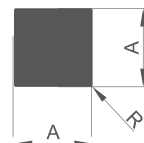

PRĘTY OKRĄGŁE			
ROUND BARS / RUNDSTANGEN			
NUMER PROFILU Profile no. Profilnr.	WYMIARY [mm] Dimensions [mm] / Abmessungen [mm]	MASA [g/m] Weight [g/m] Gewicht [g/m]	OBWÓD [mm] Perimeter [mm] Perimeter [mm]
	A		
S1333	12	305	37,70
S1560	14	416	43,98
S1194	16	543	50,27
S1288	20	848	62,83
S1264	22	1026	69,12
S1263	25	1325	78,54
S1307	26	1434	81,68
S1460	30	1909	94,25
S1486	34	2451	106,81
S1326	35	2598	109,96
S1474	50	5301	157,08
S1477	60	7634	188,50
S1571	90	17172	282,74



RURY KWADRATOWE						
SQUARE TUBES / QUADRATISCHE RÖHRE						
NUMER PROFILU Profile no. Profilnr.	WYMIARY [mm] Dimensions [mm] / Abmessungen [mm]				MASA [g/m] Weight [g/m] Gewicht [g/m]	OBWÓD [mm] Perimeter [mm] Perimeter [mm]
	A	G	R	r		
S1067	13	1	0,3	0,2	129	51,48
S1099	15	1,5	0,3	0,3	219	59,49
S1184	20	1	0,2	0,2	205	79,66
S1005	20	1,5	0,4	0,4	300	79,48
S1006	20	2	0,4	0,4	390	79,48
S1235	24	1,5	0,4	0,4	365	95,31
S1007	25	1,5	0,4	0,4	381	99,31
S1008	25	2	0,4	0,4	497	99,31
S1566	25	3	0,5	0,5	713	99,14
S1087	30	1,5	0,2	0,2	462	119,66
S1009	30	2	0,4	0,3	605	119,31
S1103	30	3	0,3	0,2	875	119,48
S1010	35	2	0,4	0,3	713	139,31
S1531	35	2	2,0	1,0	706	136,57
S1011	40	2	0,3	0,3	821	159,48
S1104	40	3	0,3	0,2	1199	159,48
S1245	40	3	2,0	0,2	1190	156,57
S1012	45	2	0,4	0,4	929	179,31
S1013	50	2	0,3	0,3	1037	199,48
S1014	50	2,5	0,4	0,4	1283	199,31
S1332	50	3	3,0	0,2	1502	194,85
S1549	50	4	4,0	0,5	1951	193,13
S1219	50	4	0,4	0,2	1987	199,31
S1015	60	2	0,4	0,4	1253	239,31
S1016	60	3	0,4	0,4	1847	239,31
S1548	60	3,5	3,0	1,0	2117	234,85
S1327	70	2	3,0	1,0	1450	274,85
S1017	80	2	0,3	0,3	1685	319,48
S1328	80	2	3,0	1,0	1666	314,85
S1244	80	4	0,4	0,3	3283	319,31
S1579	100	2	0,5	0,2	2116	399,14
S1365	100	4	0,2	0,2	4147	399,66
S1517	120	4	0,5	0,5	5011	479,14
S1518	150	4	0,5	0,5	6307	599,14

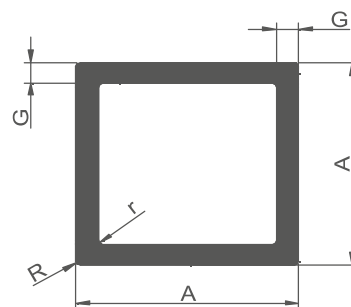

RURY PROSTOKĄTNE							
RECTANGULAR TUBES/ RECHTECKIGE RÖHRE							
NUMER PROFILU Profile no. Profilnr.	WYMIARY [mm] Dimensions [mm] / Abmessungen [mm]					MASA [g/m] Weight [g/m] Gewicht [g/m]	OBWÓD [mm] Perimeter [mm] Perimeter [mm]
	A	B	G	R	r		
S1069	18	12	1	0,3	0,2	151	59,49
S1018	20	10	1,5	0,3	0,3	219	59,48
S1068	20	13	1	0,3	0,2	168	65,66
S1309	20	15	2	0,3	0,2	334	69,48
S1019	25	15	2	0,3	0,3	389	79,48
S1545	30	10	1,5	0,3	0,2	300	79,48
S1568	30	15	2	0,3	0,2	443	89,48
S1187	30	20	1	0,2	0,2	259	99,66
S1020	30	20	2	0,4	0,4	497	99,31
S1583	40	15	1,2	2,0	0,8	333	106,57
S1551	40	20	1,2	0,3	0,2	373	119,48
S1584	40	20	1,5	2,0	0,5	462	116,56
S1021	40	20	2	0,4	0,4	605	119,31
S1260	40	20	3	0,5	0,5	875	119,14
S1095	40	25	2	1,0	0,3	657	128,28
S1289	40	25	3	0,3	0,2	956	129,48
S1276	40	30	2	0,3	0,2	713	139,49
S1287	40	30	3	0,5	0,2	1036	139,14
S1514	40	35	2,5	0,5	0,4	945	149,14
S1105	50	20	2	0,3	0,2	713	139,48
S1322	50	26	3	4,0	1,0	1099	145,13
S1022	50	30	2	0,3	0,3	821	159,49
S1023	50	30	2,5	0,3	0,3	1013	159,49
S1210	50	30	3	0,4	0,2	1198	159,31
S1227	60	20	2	0,3	0,2	821	159,48
S1274	60	25	3	0,3	0,2	1280	169,48
S1024	60	30	2	0,4	0,4	929	179,31
S1025	60	40	2	0,4	0,4	1037	199,31
S1106	60	40	2,5	0,3	0,2	1282	199,48
S1159	60	40	3	0,4	0,2	1522	199,31
S1574	60	40	4	0,5	0,2	1987	199,14
S1502	70	20	2	0,5	0,2	928	179,14
S1483	70	40	3	0,5	0,5	1685	219,14
S1358	70	40	4	0,5	0,2	2203	219,14
S1552	80	20	1,2	0,3	0,2	632	199,48
S1158	80	20	2	0,3	0,2	1037	199,48
S1070	80	40	2	0,4	0,3	1251	239,31
S1026	80	40	2,5	0,4	0,4	1553	239,31
S1258	80	40	3	0,4	0,2	1846	239,31
S1209	80	40	4	0,4	0,4	2419	239,31
S1300	80	50	2	0,2	0,2	1361	259,66
S1499	80	50	3	0,2	0,2	2009	259,66
S1330	80	50	4	0,2	0,2	2635	259,14
S1089	80	60	3	0,3	0,2	2170	279,48
S1335	90	30	3	0,2	0,2	1847	239,66
S1352	90	60	3	0,4	0,2	2332	299,31
S1186	100	20	2	0,2	0,2	1253	239,66
S1512	100	25	1,4	0,3	0,2	924	249,48
S1494	100	30	2	0,2	0,2	1361	259,66
S1246	100	40	3	2,0	0,2	2162	276,57
S1581	100	50	2	0,5	0,2	1576	299,14
S1140	100	50	4	0,5	0,2	3067	299,14
S1505	100	50	5	0,5	0,4	3780	299,14
S1504	100	70	6	0,5	0,4	5119	339,14
S1367	120	30	2	0,5	0,3	1576	299,14
S1481	120	30	3	0,2	0,2	2333	299,96
S1324	120	60	3	0,5	0,2	2818	359,14
S1108	120	60	4	0,3	0,2	3715	359,48
S1550	140	100	3	0,5	0,2	3790	479,14

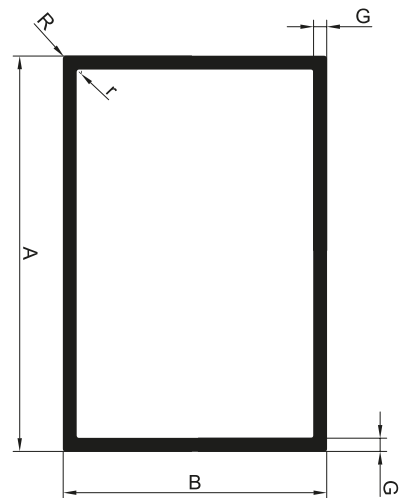

RURY OKRĄGŁE

ROUND TUBES/ RUNDE RÖHRE

NUMER PROFILU Profile no. Profilnr.	WYMIARY [mm] Dimensions [mm] / Abmessungen [mm]		MASA [g/m] Weight [g/m] Gewicht [g/m]	OBWÓD [mm] Perimeter [mm] Perimeter [mm]
	A	G		
S1249	10	2	136	31,42
S1201	12	1	93	37,70
S1266	12	2	170	37,70
S1528	14	1	110	43,98
S1567	14	1,5	159	43,98
S1343	16	1,5	184	50,26
S1334	18	1,5	210	56,55
S1169	19	1	153	59,69
S1185	20	1	161	62,83
S1231	20	1,5	235	62,83
S1000	20	2	300	62,83
S1262	20	5	636	62,83
S1048	22	1	178	69,11
S1207	22	1,5	261	69,11
S1206	23	0,9	169	72,26
S1232	25	1,5	299	78,54
S1193	25	2	390	78,54
S1237	25	3	560	78,54
S1553	28	2	441	87,96
S1001	30	2	475	94,25
S1200	30	3	687	94,25
S1252	32	2	509	100,53
S1329	32	3	738	100,53
S1251	32	5	1145	100,53
S1066	35	1,5	426	109,95
S1247	35	2	560	109,95
S1275	35	3	814	109,95
S1248	35	5	1272	109,95
S1065	40	1,5	490	125,66
S1002	40	2	644	125,66
S1259	40	2,5	795	125,66
S1261	40	3	942	125,66
S1225	42	3	992	131,95
S1291	42	8,5	2415	131,95
S1298	45	3	1069	141,37
S1319	46	3	1094	144,51
S1292	48	2	780	150,80
S1217	48	2,5	965	150,80
S1238	48	3	1145	150,80
S1239	48	4,5	1660	150,80
S1133	48,25	4	1501	151,58
S1071	50	1,5	663	157,08
S1003	50	2	814	157,08
S1004	50	3	1196	157,08
S1240	50	4	1561	157,08
S1241	50	10	3392	157,08
S1544	50	11	3639	157,08
S1135	60	2	984	188,49
S1253	60	2,5	1219	188,49
S1147	60	3	1450	188,49
S1224	60	3,5	1677	188,50
S1299	60	5	2333	188,49
S1529	60	6	2748	188,50
S1554	70	3,5	1974	219,91
S1535	70	6	3257	219,91
S1534	70	9,5	4875	219,91
S1304	75	5	2969	235,62
S1233	76	3	1858	238,76
S1511	80	2	1323	251,33
S1270	80	3	1959	251,33
S1556	80	4	2579	251,33
S1546	80	10	5938	251,33
S1575	80	30	12724	251,33
S1555	90	4	2918	282,74
S1305	90	5	3605	282,74
S1297	100	3	2468	314,16
S1557	100	4	3257	314,16
S1536	100	5	4029	314,16
S1547	100	8	6243	314,16
S1461	120	2,2	2198	376,99
S1558	120	3	2977	376,99
S1088	145	4	4784	455,53
S1515	165	3	4122	518,36

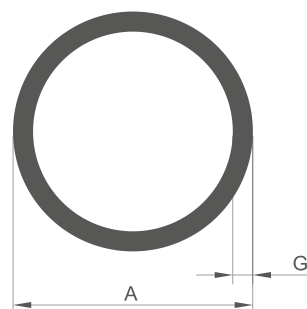

PŁASKOWNIKI

FLAT BARS / FLACHSTANGEN

NUMER PROFILU Profile no. Profilnr.	WYMIARY [mm] Dimensions [mm] / Abmessungen [mm]			MASA [g/m] Weight [g/m] Gewicht [g/m]	OBWÓD [mm] Perimeter [mm] Perimeter [mm]
	A	G	R		
S1293	12	6	0,5	194	35,14
S1339	15	3	0,2	121	35,66
S1173	15	5	0,4	202	39,31
S1109	20	2	0,3	108	43,48
S1049	20	3	0,3	162	45,49
S1519	20	4	0,3	216	47,49
S1050	20	5	0,3	270	49,49
S1051	20	10	0,3	540	59,49
S1500	28	7	0,2	529	69,66
S1204	30	2	0,2	162	63,66
S1052	30	3	0,3	243	65,49
S1053	30	5	0,5	404	69,14
S1497	30	8	0,5	647	75,14
S1054	30	10	0,3	810	79,49
S1286	30	15	0,3	1215	89,48
S1278	30	20	0,3	1620	99,48
S1230	35	3	0,3	283	75,49
S1055	40	3	0,3	324	85,49
S1056	40	5	0,5	539	89,14
S1295	40	8	0,5	863	95,14
S1057	40	10	0,5	1079	99,14
S1205	50	2	0,2	270	103,66
S1516	50	4	0,3	540	107,49
S1058	50	5	0,5	674	109,14
S1369	50	8	0,2	1080	115,66
S1370	50	8,5	0,2	1147	116,66
S1371	50	9	0,2	1215	117,66
S1372	50	9,5	0,2	1282	118,66
S1059	50	10	0,3	1350	119,49
S1373	50	10	0,3	1350	119,49
S1374	50	10,5	0,3	1417	120,49
S1375	50	11	0,3	1485	121,49
S1376	50	11,5	0,3	1552	122,49
S1377	50	12	0,3	1620	123,49
S1378	50	12,5	0,4	1687	124,31
S1379	50	13	0,4	1755	125,31
S1380	50	13,5	0,4	1822	126,31
S1381	50	14	0,4	1890	127,31
S1382	50	14,5	0,4	1957	128,31
S1383	50	15	0,4	2025	129,31
S1384	50	15,5	0,4	2092	130,31
S1385	50	16	0,4	2160	131,31
S1386	50	16,5	0,4	2227	132,31
S1387	50	17	0,4	2295	133,31
S1388	50	17,5	0,4	2362	134,31
S1389	50	18	0,4	2430	135,31
S1390	50	18,5	0,5	2497	136,14
S1391	50	19	0,5	2564	137,14

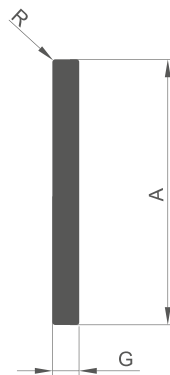

PŁASKOWNIKI

FLAT BARS / FLACHSTANGEN

NUMER PROFILU Profile no. Profilnr.	WYMIARY [mm] Dimensions [mm] / Abmessungen [mm]			MASA [g/m] Weight [g/m] Gewicht [g/m]	OBWÓD [mm] Perimeter [mm] Perimeter [mm]
	A	G	R		
S1392	50	19,5	0,5	2632	138,14
S1393	50	20	0,5	2699	139,14
S1394	50	20,5	0,5	2767	140,14
S1395	50	21	0,5	2834	141,14
S1396	50	21,5	0,5	2902	142,14
S1397	50	22	0,5	2969	143,14
S1398	50	22,5	0,5	3037	144,14
S1399	50	23	0,5	3104	145,14
S1400	50	23,5	0,5	3172	146,14
S1401	50	24	0,5	3239	147,14
S1402	50	24,5	0,5	3307	148,14
S1403	50	25	0,5	3374	149,14
S1404	50	25,5	0,5	3442	150,14
S1405	50	26	0,5	3509	151,14
S1406	50	26,5	0,5	3577	152,14
S1407	50	27	0,5	3644	153,14
S1408	50	27,5	0,5	3712	154,14
S1409	50	28	0,5	3779	155,14
S1410	50	28,5	0,5	3847	156,14
S1411	50	29	0,5	3914	157,14
S1412	50	29,5	0,5	3982	158,14
S1413	50	30	0,5	4049	159,14
S1414	50	30,5	0,5	4117	160,14
S1415	50	31	0,5	4184	161,14
S1416	50	31,5	0,5	4252	162,14
S1417	50	32	0,5	4319	163,14
S1418	50	32,5	0,5	4387	164,14
S1419	50	33	0,5	4454	165,14
S1420	50	33,5	0,5	4522	166,14
S1421	50	34	0,5	4589	167,14
S1422	50	34,5	0,5	4657	168,14
S1423	50	35	0,5	4724	169,14
S1424	50	35,5	0,5	4792	170,14
S1425	50	36	0,5	4859	171,14
S1426	50	36,5	0,5	4927	172,14
S1427	50	37	0,5	4994	173,14
S1428	50	37,5	0,5	5062	174,14
S1429	50	38	0,5	5129	175,14
S1430	50	38,5	0,5	5197	176,14
S1431	50	39	0,5	5264	177,14
S1432	50	39,5	0,5	5332	178,14
S1433	50	40	0,5	5399	179,14
S1434	50	40,5	0,5	5467	180,14
S1435	50	41	0,5	5534	181,14
S1436	50	41,5	0,5	5602	182,14
S1437	50	42	0,5	5669	183,14
S1438	50	42,5	0,5	5737	184,14
S1439	50	43	0,5	5804	185,14
S1440	50	43,5	0,5	5872	186,14
S1060	60	5	0,5	809	129,14
S1061	60	10	0,3	1620	139,50
S1294	60	15	0,5	2429	149,14
S1325	60	20	1,0	3238	158,28
S1321	60	25	0,6	4049	168,97
S1559	60	30	1,0	4857	178,46
S1331	65	10	0,3	1755	149,49
S1306	70	5	0,3	945	149,49
S1283	70	10	0,3	1890	159,48
S1533	70	12	0,5	2267	163,14
S1462	75	8	0,5	1619	165,14
S1445	75	12	0,5	2429	173,14
S1463	75	16	0,5	3239	181,14
S1446	75	20	0,5	4049	189,14
S1447	75	25	0,5	5062	199,14
S1448	75	30	0,5	6074	209,14
S1449	75	37	0,5	7492	223,14
S1062	80	5	0,3	1080	169,49
S1349	80	8	0,5	1727	175,14
S1063	80	10	0,3	2160	179,49
S1281	80	20	0,3	4320	199,48

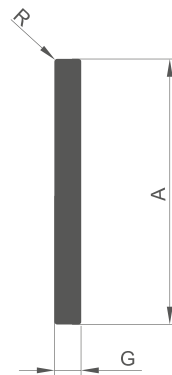

PŁASKOWNIKI

FLAT BARS / FLACHSTANGEN

NUMER PROFILU Profile no. Profilnr.	WYMIARY [mm] Dimensions [mm] / Abmessungen [mm]			MASA [g/m] Weight [g/m] Gewicht [g/m]	OBWÓD [mm] Perimeter [mm] Perimeter [mm]
	A	G	R		
S1348	100	3	0,3	810	205,48
S1064	100	5	0,3	1350	209,48
S1464	100	7,5	1,0	2023	213,28
S1154	100	10	0,5	2699	219,14
S1465	100	10	1,0	2698	218,28
S1450	100	11,5	1,0	3103	221,28
S1280	100	15	0,3	4050	229,48
S1466	100	16	1,0	4318	230,28
S1284	100	20	0,3	5400	239,48
S1451	100	20	1,0	5399	239,14
S1452	100	25	1,0	6749	249,14
S1453	100	30	1,0	8099	259,14
S1467	100	33	1,0	8908	264,28
S1364	120	10	0,5	3239	259,14
S1532	120	12	0,5	3887	263,14
S1468	200	7,5	1,0	4048	413,28
S1469	200	10	1,0	5398	418,28
S1455	200	11,5	1,0	6208	421,28
S1470	200	16	1,0	8638	430,28



PROFILE SPECJALNE

PROFILE SPECJALNE DO POLIWĘGLANÓW					
SPECIAL PROFILES FOR POLYCARBONATES / SONDERPROFILE FÜR POLYCARBONATE					
NUMER PROFILU Profile no. Profilnr.	WYMIARY [mm] Dimensions [mm] / Abmessungen [mm]			MASA [g/m] Weight [g/m] Gewicht [g/m]	OBWÓD [mm] Perimeter [mm] Perimeter [mm]
	A	B	C		
S1145	39,4	21,4	25,2	288	168,87
S1144	34,4	21,4	20,2	270	158,87
S1072	30,4	21,4	16,2	248	145,87
S1094	24,4	21,4	10,2	226	133,87
S1143	22,4	21,4	8,2	225	132,87
S1142	20,4	21,4	6,2	212	125,87

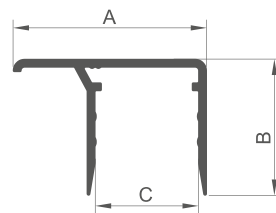

NUMER PROFILU Profile no. Profilnr.	WYMIARY [mm] Dimensions [mm] / Abmessungen [mm]					MASA [g/m] Weight [g/m] Gewicht [g/m]	OBWÓD [mm] Perimeter [mm] Perimeter [mm]
	A	B	C	D	E		
S1075	34,8	66,8	12	17,6	29,6	716	275,65
S1078	34,8	66,8	18	23,6	35,6	746	287,27
S1079	34,8	66,8	22	27,6	39,6	766	295,45

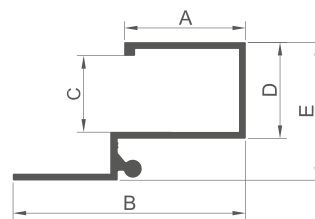

NUMER PROFILU Profile no. Profilnr.	WYMIARY [mm] Dimensions [mm] / Abmessungen [mm]		MASA [g/m] Weight [g/m] Gewicht [g/m]	OBWÓD [mm] Perimeter [mm] Perimeter [mm]
	A	B		
S1073	58,8	7	302	150,62

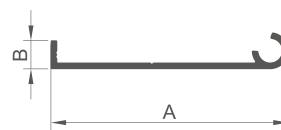

NUMER PROFILU Profile no. Profilnr.	WYMIARY [mm] Dimensions [mm] / Abmessungen [mm]		MASA [g/m] Weight [g/m] Gewicht [g/m]	OBWÓD [mm] Perimeter [mm] Perimeter [mm]
	A	B		
S1076	60	9	388	182,49

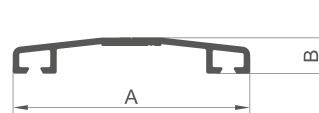

NUMER PROFILU Profile no. Profilnr.	WYMIARY [mm] Dimensions [mm] / Abmessungen [mm]		MASA [g/m] Weight [g/m] Gewicht [g/m]	OBWÓD [mm] Perimeter [mm] Perimeter [mm]
	A	B		
S1074	60	19,6	744	282,38
S1271	60	17	667	275,59

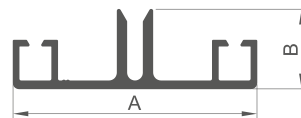

NUMER PROFILU Profile no. Profilnr.	WYMIARY [mm] Dimensions [mm] / Abmessungen [mm]		MASA [g/m] Weight [g/m] Gewicht [g/m]	OBWÓD [mm] Perimeter [mm] Perimeter [mm]
	A	B		
S1077	60	60	1351	430,2

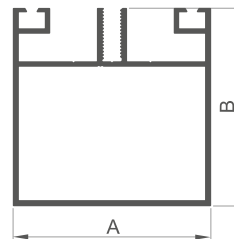

PROFILE SPECJALNE DO POLIWĘGLANÓW - ZASTOSOWANIE

SPECIAL PROFILES FOR POLICARBONATES - USAGE

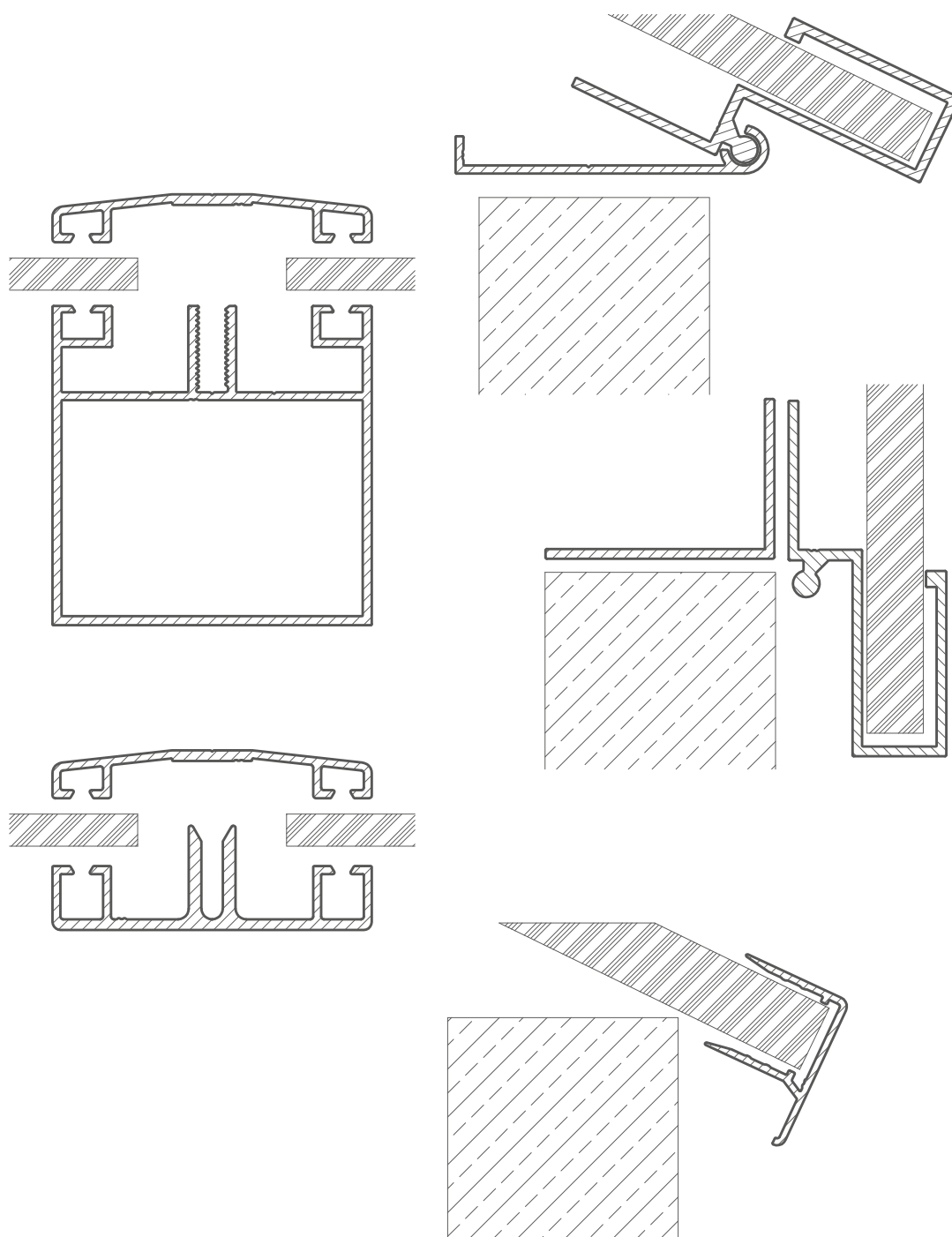

PROFILE SPECJALNE DO REKLAM

**SPECIAL PROFILES FOR ADVERTISEMENT
SONDERPROFILE FÜR WERBUNGSBRANCHE**

NUMER PROFILU Profile no. Profilnr.	MASA [kg/m] Weight [kg/m] Gewicht [kg/m]	OBWÓD [mm] Perimeter [mm] Perimeter [mm]
S1080	1,036	298,23

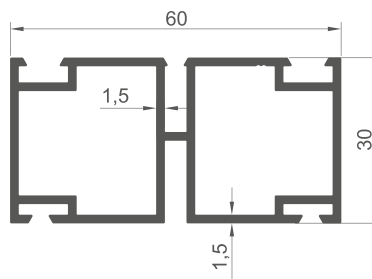

NUMER PROFILU Profile no. Profilnr.	MASA [kg/m] Weight [kg/m] Gewicht [kg/m]	OBWÓD [mm] Perimeter [mm] Perimeter [mm]
S1090	0,253	125,01

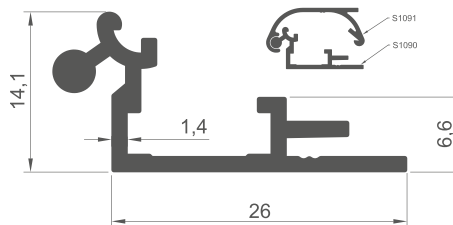

NUMER PROFILU Profile no. Profilnr.	MASA [kg/m] Weight [kg/m] Gewicht [kg/m]	OBWÓD [mm] Perimeter [mm] Perimeter [mm]
S1091	0,241	121,03

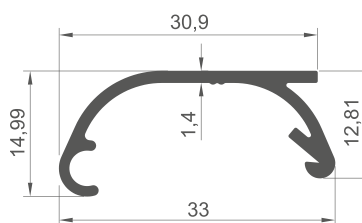

NUMER PROFILU Profile no. Profilnr.	MASA [kg/m] Weight [kg/m] Gewicht [kg/m]	OBWÓD [mm] Perimeter [mm] Perimeter [mm]
S1136	1,216	231,41

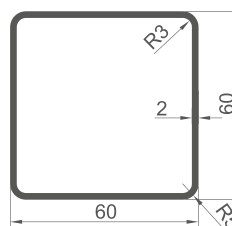

NUMER PROFILU Profile no. Profilnr.	MASA [kg/m] Weight [kg/m] Gewicht [kg/m]	OBWÓD [mm] Perimeter [mm] Perimeter [mm]
S1092	1,477	597,35

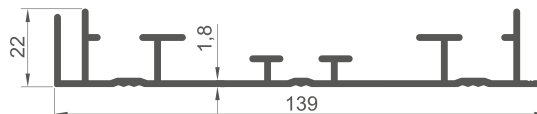

NUMER PROFILU Profile no. Profilnr.	MASA [kg/m] Weight [kg/m] Gewicht [kg/m]	OBWÓD [mm] Perimeter [mm] Perimeter [mm]
S1093	0,911	215,66

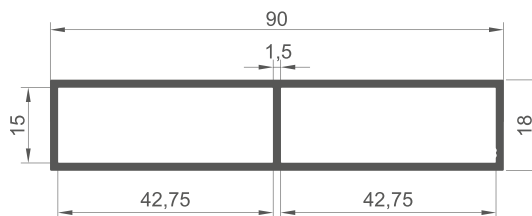

PROFILE SPECJALNE DO KLIMATYZACJI

SPECIAL PROFILES FOR AIR CONDITIONING AND VENTING
SONDERPROFILE FÜR KLIMASYSTEME

NUMER PROFILU Profile no. Profilnr.	MASA [kg/m] Weight [kg/m] Gewicht [kg/m]	OBWÓD [mm] Perimeter [mm] Perimeter [mm]
S1138	1,251	278,37

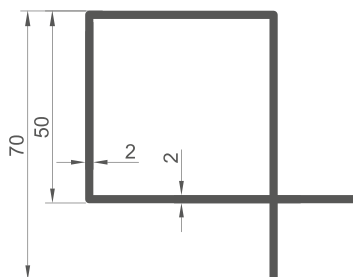

NUMER PROFILU Profile no. Profilnr.	MASA [kg/m] Weight [kg/m] Gewicht [kg/m]	OBWÓD [mm] Perimeter [mm] Perimeter [mm]
S1139	1,250	281,94

NUMER PROFILU Profile no. Profilnr.	MASA [kg/m] Weight [kg/m] Gewicht [kg/m]	OBWÓD [mm] Perimeter [mm] Perimeter [mm]
S1192	0,610	198,03

NUMER PROFILU Profile no. Profilnr.	MASA [kg/m] Weight [kg/m] Gewicht [kg/m]	OBWÓD [mm] Perimeter [mm] Perimeter [mm]
S1208	1,035	248,20

NUMER PROFILU Profile no. Profilnr.	MASA [kg/m] Weight [kg/m] Gewicht [kg/m]	OBWÓD [mm] Perimeter [mm] Perimeter [mm]
S1226	0,823	237,69

NUMER PROFILU Profile no. Profilnr.	MASA [g/m] Weight [g/m] Gewicht [g/m]	OBWÓD [mm] Perimeter [mm] Perimeter [mm]
S1191	0,621	197,97

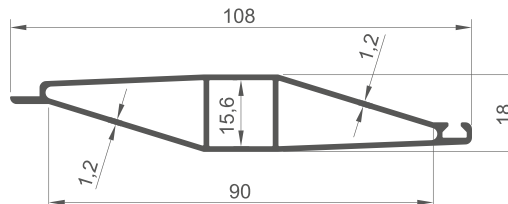
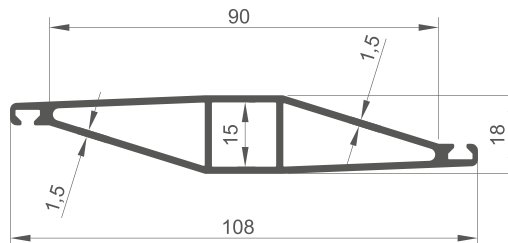
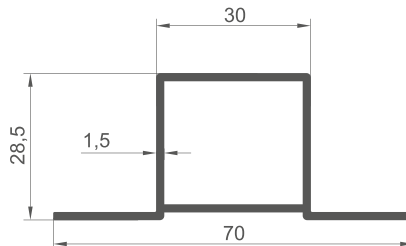
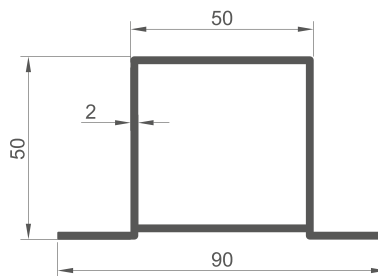
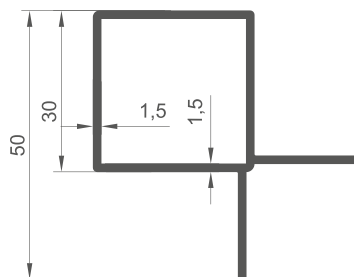

PROFILE SPECJALNE - ELEWACYJNE

SPECIAL PROFILES - FACADE CONSTRUCTIONS
SONDERPROFILE - FASSADEN

NUMER PROFILU Profile no. Profilnr.	MASA [kg/m] Weight [kg/m] Gewicht [kg/m]	OBWÓD [mm] Perimeter [mm] Perimeter [mm]
S1114	1,028	411,09

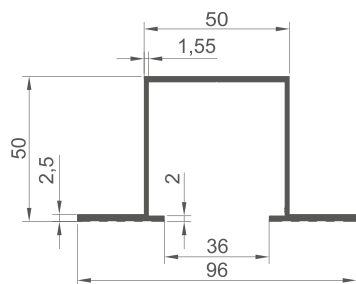

NUMER PROFILU Profile no. Profilnr.	MASA [kg/m] Weight [kg/m] Gewicht [kg/m]	OBWÓD [mm] Perimeter [mm] Perimeter [mm]
S1359	1,091	407,31

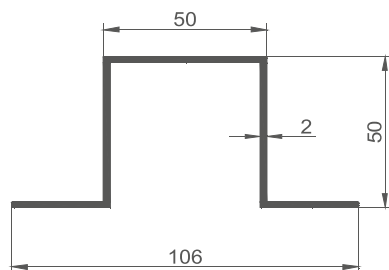

NUMER PROFILU Profile no. Profilnr.	MASA [kg/m] Weight [kg/m] Gewicht [kg/m]	OBWÓD [mm] Perimeter [mm] Perimeter [mm]
S1354	0,837	312,57

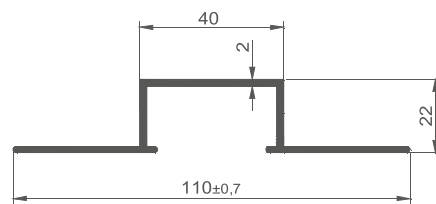

NUMER PROFILU Profile no. Profilnr.	MASA [kg/m] Weight [kg/m] Gewicht [kg/m]	OBWÓD [mm] Perimeter [mm] Perimeter [mm]
S1340	0,598	239,56

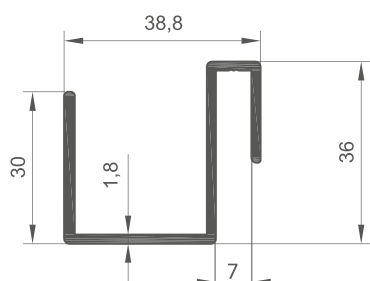

NUMER PROFILU Profile no. Profilnr.	MASA [kg/m] Weight [kg/m] Gewicht [kg/m]	OBWÓD [mm] Perimeter [mm] Perimeter [mm]
S1565	0,629	251,02

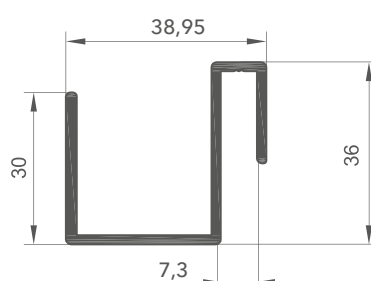

NUMER PROFILU Profile no. Profilnr.	MASA [kg/m] Weight [kg/m] Gewicht [kg/m]	OBWÓD [mm] Perimeter [mm] Perimeter [mm]
S1166	1,956	441,09

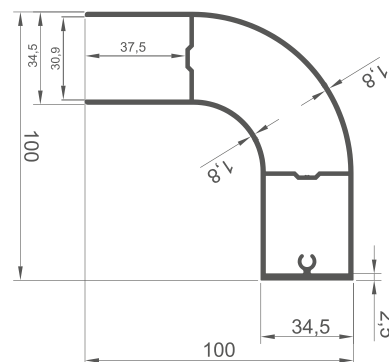

NUMER PROFILU Profile no. Profilnr.	MASA [kg/m] Weight [kg/m] Gewicht [kg/m]	OBWÓD [mm] Perimeter [mm] Perimeter [mm]
S1520	3,947	521,88

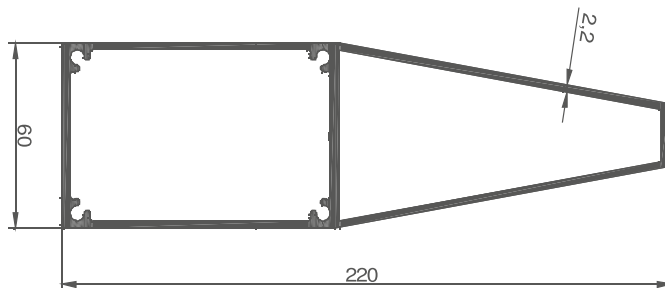

NUMER PROFILU Profile no. Profilnr.	MASA [kg/m] Weight [kg/m] Gewicht [kg/m]	OBWÓD [mm] Perimeter [mm] Perimeter [mm]
S1342	0,555	228,47

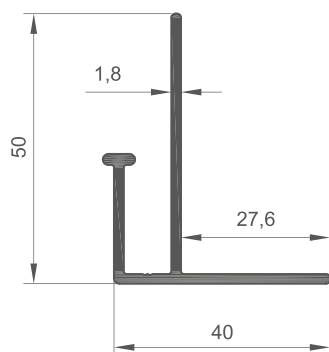

NUMER PROFILU Profile no. Profilnr.	MASA [kg/m] Weight [kg/m] Gewicht [kg/m]	OBWÓD [mm] Perimeter [mm] Perimeter [mm]
S1341	0,663	267,64

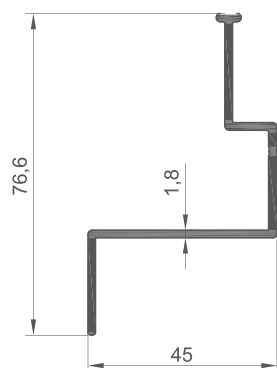

NUMER PROFILU Profile no. Profilnr.	MASA [kg/m] Weight [kg/m] Gewicht [kg/m]	OBWÓD [mm] Perimeter [mm] Perimeter [mm]
S1473	0,858	347,29

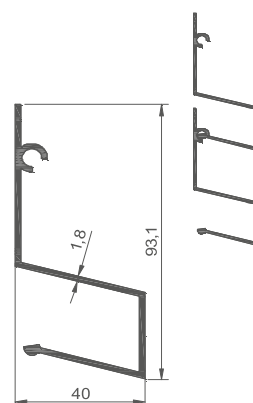

PROFILE SPECJALNE DO ZABUDOWY POJAZDÓW
SPECIAL PROFILES FOR VEHICLE CONSTRUCTIONS
SONDERPROFILE FÜR FAHRZEUGBAU

NUMER PROFILU Profile no. Profilnr.	MASA [kg/m] Weight [kg/m] Gewicht [kg/m]	OBWÓD [mm] Perimeter [mm] Perimeter [mm]
S1164	1,207	307,98

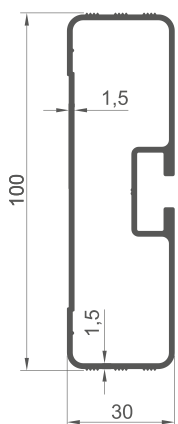

NUMER PROFILU Profile no. Profilnr.	MASA [kg/m] Weight [kg/m] Gewicht [kg/m]	OBWÓD [mm] Perimeter [mm] Perimeter [mm]
S1165	1,553	296,59

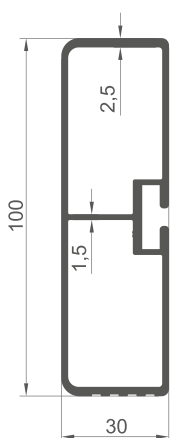

NUMER PROFILU Profile no. Profilnr.	MASA [kg/m] Weight [kg/m] Gewicht [kg/m]	OBWÓD [mm] Perimeter [mm] Perimeter [mm]
S1250	1,233	312,02

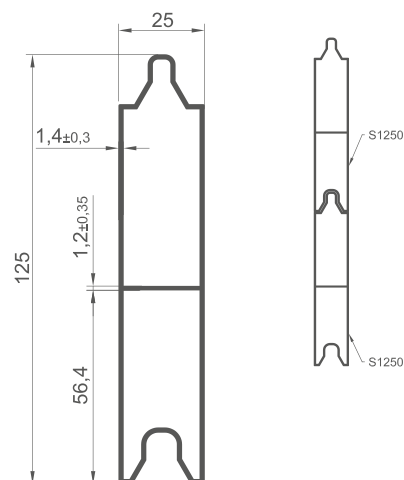

NUMER PROFILU Profile no. Profilnr.	MASA [kg/m] Weight [kg/m] Gewicht [kg/m]	OBWÓD [mm] Perimeter [mm] Perimeter [mm]
S1478	1,162	425,56

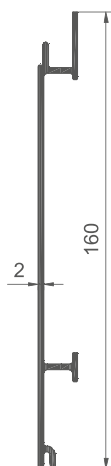

NUMER PROFILU Profile no. Profilnr.	MASA [kg/m] Weight [kg/m] Gewicht [kg/m]	OBWÓD [mm] Perimeter [mm] Perimeter [mm]
S1564	0,521	242,63

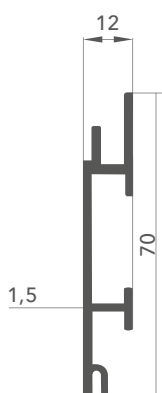

NUMER PROFILU Profile no. Profilnr.	MASA [kg/m] Weight [kg/m] Gewicht [kg/m]	OBWÓD [mm] Perimeter [mm] Perimeter [mm]
S1199	3,073	599,00

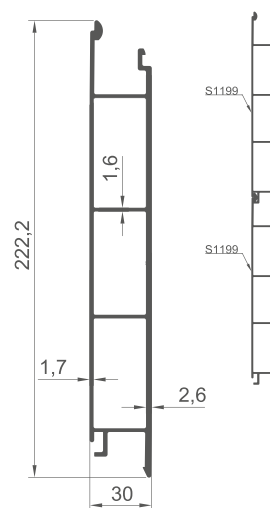

NUMER PROFILU Profile no. Profilnr.	MASA [kg/m] Weight [kg/m] Gewicht [kg/m]	OBWÓD [mm] Perimeter [mm] Perimeter [mm]
S1168	2,739	498,93

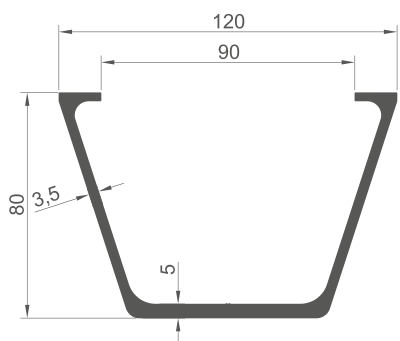

NUMER PROFILU Profile no. Profilnr.	MASA [kg/m] Weight [kg/m] Gewicht [kg/m]	OBWÓD [mm] Perimeter [mm] Perimeter [mm]
S1167	5,141	510,38

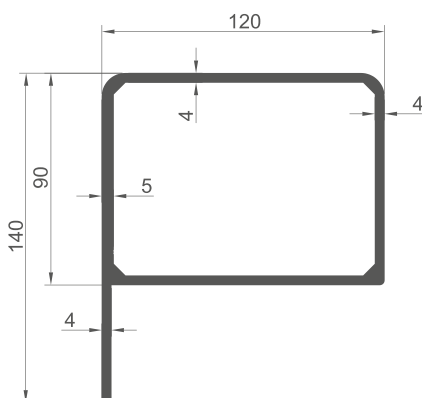

PROFILE SPECJALNE - NAMIOTY

SPECIAL PROFILES - TENTS CONSTRUCTIONS
SONDERPROFILE - ZELTKONSTRUKTIONEN

NUMER PROFILU Profile no. Profilnr.	MASA [kg/m] Weight [kg/m] Gewicht [kg/m]	OBWÓD [mm] Perimeter [mm] Perimeter [mm]
S1223	4,708	648,14

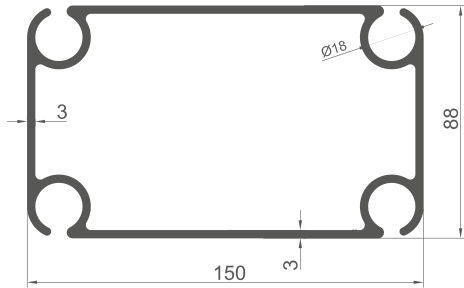

NUMER PROFILU Profile no. Profilnr.	MASA [kg/m] Weight [kg/m] Gewicht [kg/m]	OBWÓD [mm] Perimeter [mm] Perimeter [mm]
S1229	1,542	286,52

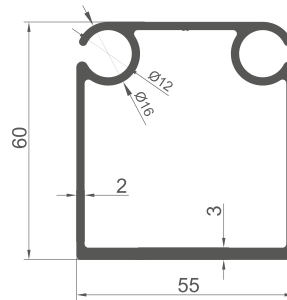

PROFILE SPECJALNE - OŚWIETLENIE LED ORAZ INSTALACJE KABLOWE

SPECIAL PROFILES - LED LIGHTING AND CABLE INSTALATIONS
SONDERPROFILE - LED-BELEUCHTUNG UND KABELANLAGEN

NUMER PROFILU Profile no. Profilnr.	MASA [kg/m] Weight [kg/m] Gewicht [kg/m]	OBWÓD [mm] Perimeter [mm] Perimeter [mm]
S1487	1,433	596,42
S1488	0,387	155,12

NUMER PROFILU Profile no. Profilnr.	MASA [kg/m] Weight [kg/m] Gewicht [kg/m]	OBWÓD [mm] Perimeter [mm] Perimeter [mm]
S1509	1,340	644,32
S1510	0,288	154,05

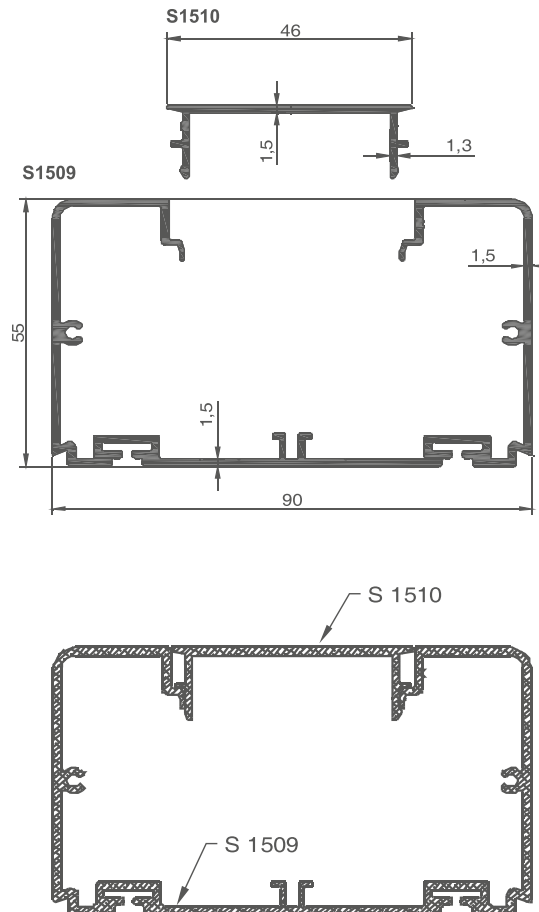
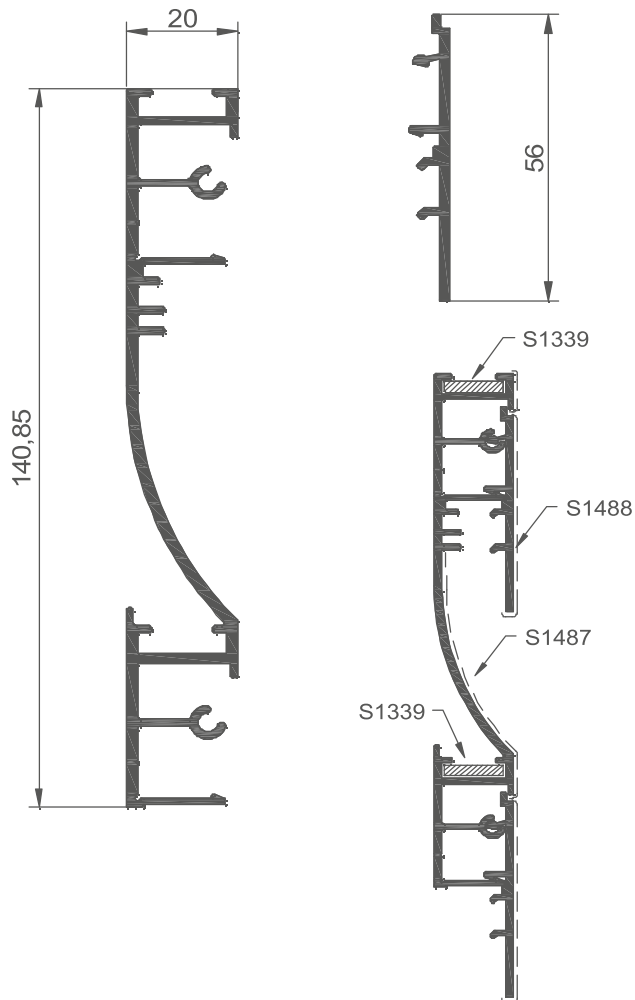

PROFILE SPECJALNE - DRABINY

SPECIAL PROFILES - LADDERS / SONDERPROFILE - LEITERBAU

NUMER PROFILU Profile no. Profilnr.	MASA [kg/m] Weight [kg/m] Gewicht [kg/m]	OBWÓD [mm] Perimeter [mm] Perimeter [mm]
S1345	0,604	169,66

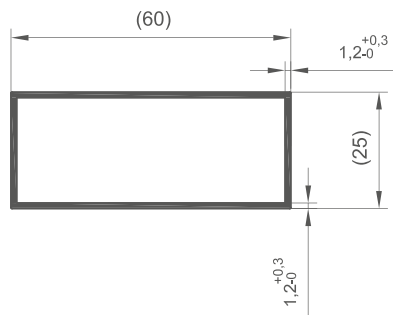

NUMER PROFILU Profile no. Profilnr.	MASA [kg/m] Weight [kg/m] Gewicht [kg/m]	OBWÓD [mm] Perimeter [mm] Perimeter [mm]
S1346	0,738	205,71

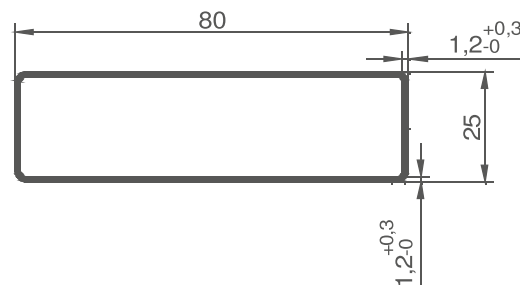

NUMER PROFILU Profile no. Profilnr.	MASA [kg/m] Weight [kg/m] Gewicht [kg/m]	OBWÓD [mm] Perimeter [mm] Perimeter [mm]
S1347	0,342	130,17

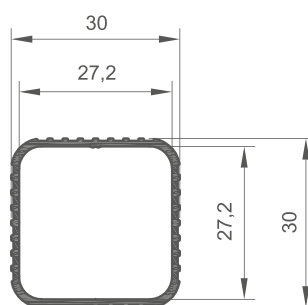

PROFILE O SPECJALNYM ZASTOSOWANIU

ALUMINIUM PROFILES FOR SPECIAL USE
SONDERPROFILE FÜR SPEZIELLANWENDUNG

NUMER PROFILU Profile no. Profilnr.	MASA [kg/m] Weight [kg/m] Gewicht [kg/m]	OBWÓD [mm] Perimeter [mm] Perimeter [mm]
S1242	0,237	50,26

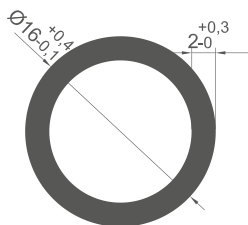

NUMER PROFILU Profile no. Profilnr.	MASA [kg/m] Weight [kg/m] Gewicht [kg/m]	OBWÓD [mm] Perimeter [mm] Perimeter [mm]
S1503	0,338	209,76

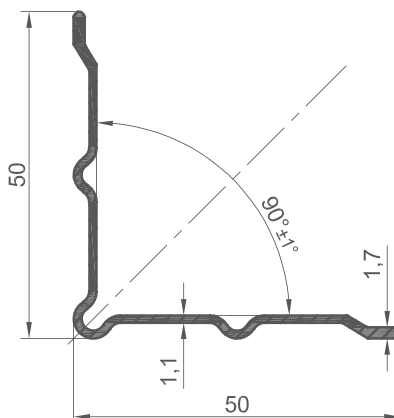

NUMER PROFILU Profile no. Profilnr.	MASA [kg/m] Weight [kg/m] Gewicht [kg/m]	OBWÓD [mm] Perimeter [mm] Perimeter [mm]
S1257	2,153	151,74

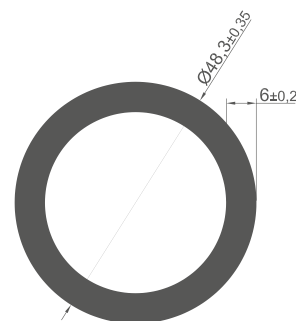

PROFILE SPECJALNE DO FOTOWOLTAIKI

SPECIAL PROFILES FOR PHOTOVOLTAICS
SONDERPROFILE FÜR PHOTOVOLTAIK

NUMER PROFILU Profile no. Profilnr.	MASA [kg/m] Weight [kg/m] Gewicht [kg/m]	OBWÓD [mm] Perimeter [mm] Perimeter [mm]
S1537	1,107	350,18

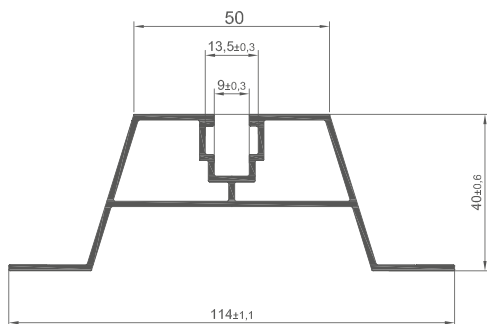

NUMER PROFILU Profile no. Profilnr.	MASA [kg/m] Weight [kg/m] Gewicht [kg/m]	OBWÓD [mm] Perimeter [mm] Perimeter [mm]
S1538	0,882	234,91

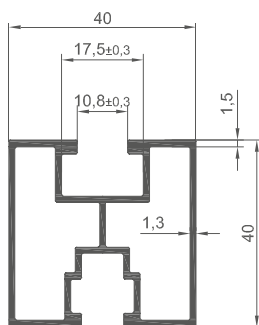

NUMER PROFILU Profile no. Profilnr.	MASA [kg/m] Weight [kg/m] Gewicht [kg/m]	OBWÓD [mm] Perimeter [mm] Perimeter [mm]
S1539	0,468	130,24

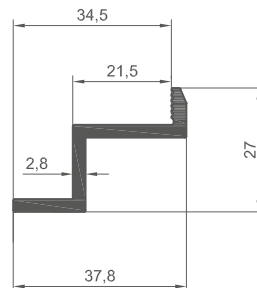
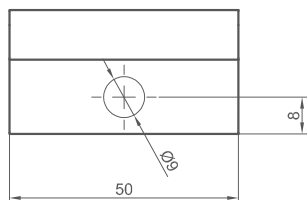

NUMER PROFILU Profile no. Profilnr.	MASA [kg/m] Weight [kg/m] Gewicht [kg/m]	OBWÓD [mm] Perimeter [mm] Perimeter [mm]
S1540	0,540	165,76

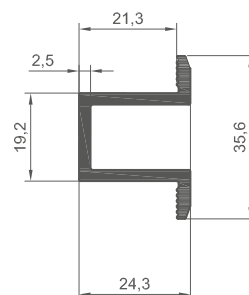
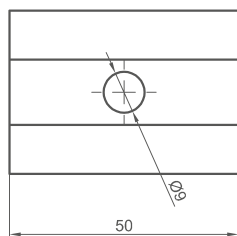

NUMER PROFILU Profile no. Profilnr.	MASA [kg/m] Weight [kg/m] Gewicht [kg/m]	OBWÓD [mm] Perimeter [mm] Perimeter [mm]
S1542	0,609	184,83

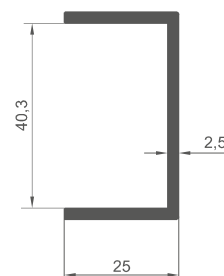
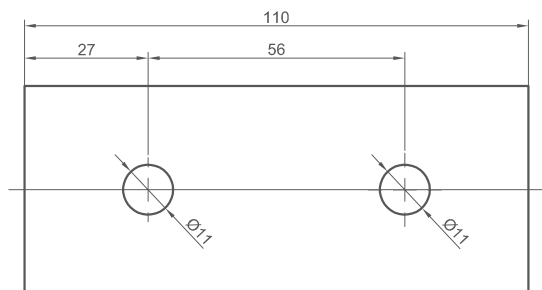

WŁASNOŚCI MECHANICZNE

MECHANICAL PROPERTIES

OZNACZENIE STANÓW (wg EN 515)

TEMPER SYMBOLS (according to EN 515)

F	Wytworzony (surowy) (bez określonych własności mechanicznych) Extruded and air cooled (without mechanical properties specified)
H112	Lekko umocniony przez kształtowanie w podwyższonej temperaturze (określony poziom własności mechanicznych) Softly strengthen by shaping in higher temperature (specified mechanical properties limits)
T4	Przesycony i naturalnie starzony Heat treated and naturally aged
T5	Schłodzony z podwyższonej temperatury procesu kształtowania, sztucznie starzony Cooled from extrusion temperature and artificially aged
T64	Przesycony i sztucznie starzony Heat treated and artificially aged
T6	Przesycony i sztucznie starzony w temperaturze jak dla stanu pod starzonego Heat treated and artificially aged
T66	Przesycony i sztucznie starzony- poziom własności mechanicznych wyższy niż w stanie T6 Heat treated and artificially aged level of mechanical properties higher than in temper T6

OZNACZENIE WŁASNOŚCI MECHANICZNYCH

TEMPER MECHANICAL PROPERTIES

R _m	Wytrzymałość na rozciąganie Tensile strength
R _{p0.2}	Umowna granica plastyczności Yield strength
A%	Wydłużenie przy zerwaniu próbki dla bazy pomiarowej 5,65 √ S₀ (S₀ - pole przekroju próbki), wyrażone w%/ Elongation measured on a gauge length of 5,65 √ S ₀ (S ₀ - cross section of the sample) and expressed in%/
A50	Wydłużenie zmierzone na długości pomiarowej 50mm, wyrażone w%/ Elongation measured on a gauge length of 50mm and expressed in % /

PRĘTY, RURY, KSZTAŁTOWNIKI WYCISKANE I NIEWYSPECYFIKOWANE

BARS, TUBES, EXTRUDED PROFILES AND NOT SPECIFIED

STAN State	WYMIAR [mm] Dimension [mm]		Rm [MPa]	Rp _{0.2} [MPa]	A	A _{50mm}	HBW WARTOŚĆ TYPOWA Typical value
	D ^a	S ^a	min	min	% min	% min	
EN AW-1070A [Al 99,7] - PRĘTY, RURY, KSZTAŁTOWNIKI WYCISKANE I NIEWYSPECYFIKOWANE / BARS, TUBES, EXTRUDED PROFILES AND NOT SPECIFIED							
F5,H112	do ustalenia / to agree	do ustalenia / to agree	60	23	25	23	18

a D=Średnica dla pręta okrągłego/ Diameter for round bar

b S=Wymiar pod klucz dla pręta kwadratowego i sześciokątnego, grubość dla pręta prostokątnego/ Width cross section for square and hexagonal bar, thickness for rectangular bar
c Stan F : wartości własności podano wyłącznie w celu informacyjnym/ F temper- properties given just as the information

PRĘTY WYCISKANE

EXTRUDED BARS

STAN State	WYMIAR [mm] Dimension [mm]		Rm [MPa]	Rp _{0.2} [MPa]	A	A _{50mm}	HBW WARTOŚĆ TYPOWA Typical value
	D ^a	S ^a	min	min	% min	% min	
EN AW-6060 [Al MgSi] - PRĘTY WYCISKANE / EXTRUDED BARS							
T4	≤150	≤150	120	60	16	14	50
T5			160	120	8	6	60
T64 ^{cd}	≤50	≤50	180	120	12	10	60
T6	≤150	≤150	190	150	8	6	70
T66			215	160	8	6	75
EN AW-6063 [Al Mg0,7Si] - PRĘTY WYCISKANE / EXTRUDED BARS							
T4	≤150	≤150	130	65	14	12	50
	150<D≤200	150<D≤200	120	65	12	-	50
T5	≤200	≤200	175	130	8	6	65
T6	≤150	≤150	215	170	10	8	75
	150<D≤200	150<S≤200	195	160	10	-	75
T66	≤200	≤200	245	200	10	8	80
EN AW-6005A [Al SiMg(A)] - PRĘTY WYCISKANE / EXTRUDED BARS							
T6	≤25	≤25	270	225	10	8	90
	25<D≤50	25<S≤50	270	225	8	-	90
	50<D≤100	50<S≤100	260	215	8	-	85
EN AW-6082 [Al Si MgMn] - PRĘTY WYCISKANE / EXTRUDED BARS							
T4	≤200	≤200	205	110	14	12	70
T6	≤20	≤20	295	250	8	6	95
	20<D≤150	20<S≤150	310	260	8	-	95
	150<D≤200	150<S≤200	280	240	6	-	95
	200<D≤250	200<S≤250	270	200	6	-	95

a D=Średnica dla pręta okrągłego/ Diameter for round bar

b S=Wymiar pod klucz dla pręta kwadratowego i sześciokątnego, grubość dla pręta prostokątnego/ Width cross section for square and hexagonal bar, thickness for rectangular bar.

d Materiał przeznaczony do gięcia/ Material for bending

RURY WYCISKANE

EXTRUDED TUBES

STAN State	GRUBOŚĆ ŚCIANKI Wall thickness [mm]	Rm [MPa]	Rp _{0.2} [MPa]	A	A _{50mm}	HBW WARTOŚĆ TYPOWA Typical value
		min	min	% min	% min	
EN AW-6060 [Al MgSi] - RURY WYCISKANE/ EXTRUDED TUBES						
T4	≤15	120	60	16	14	50
T5		160	120	8	6	60
T64 ^{cd}		180	120	12	10	60
T6		190	150	8	6	70
T66		215	160	8	6	75
		245	200	10	8	80
EN AW-6063 [Al Mg0,7Si] - RURY WYCISKANE/ EXTRUDED TUBES						
T4 ^c	≤10	130	65	14	12	50
	10<t≤25	120	65	12	10	50
T5	≤25	175	130	8	6	65
T6		215	170	10	8	75
T66		245	200	10	8	80
EN AW-6005A [Al SiMg(A)] - RURY WYCISKANE/ EXTRUDED TUBES						
T6	≤5	270	225	8	6	90
	5<t≤10	260	215	8	6	85
EN AW-6082 [Al Si1 MgMn] - RURY WYCISKANE/ EXTRUDED TUBES						
T4	≤25	205	110	14	12	70
T6	≤5	290	250	8	6	95
	5<t≤10	310	260	10	8	95

d Materiał przeznaczony do gięcia/ Material for bending

KSZTAŁTOWNIKI WYCISKANE

EXTRUDED PROFILES

STAN State	GRUBOŚĆ ŚCIANKI Wall thickness [mm]	Rm [MPa]	Rp _{0,2} [MPa]	A	A _{50mm}	HBW WARTOŚĆ TYPOWA Typical value
		min	min	% min	% min	
EN AW-6060*[Al MgSi] - KSZTAŁTOWNIKI WYCISKANE/ EXTRUDED PROFILES						
T4	≤25	120	60	16	14	50
T5	≤5	160	120	8	6	60
	5<t≤25	140	100	8	6	60
T64 ^d	≤15	180	120	12	10	60
T6	≤3	190	150	8	6	70
	3<t≤25	170	140	8	6	70
T66	≤3	215	160	8	6	75
	3<t≤25	195	150	8	6	75
EN AW-6063*[Al Mg0, 7Si] - KSZTAŁTOWNIKI WYCISKANE/ EXTRUDED PROFILES						
T4	≤25	130	65	14	12	50
T5	≤5	175	130	8	6	65
	5<t≤25	160	110	7	5	65
T64 ^d	≤15	180	120	12	10	65
T6	≤10	215	170	8	6	75
	10<t≤25	195	160	8	6	75
T66	≤10	245	200	8	6	80
	10<t≤25	225	180	8	6	80
EN AW-6005A*[Al SiMg(Al)] - KSZTAŁTOWNIKI WYCISKANE/ EXTRUDED PROFILES						
Profile otwarte T4 ^c / Fiat profiles T4	≤25	180	90	15	13	50
	≤5	270	225	8	6	90
Profile otwarte T6 ^c / Fiat profiles T6	5<t≤10	260	215	8	6	85
	10<t≤25	250	200	8	6	85
Profile zamknięte T4 / Hollow profiles T4	≤10	180	90	15	13	50
Profile zamknięte T6 / Hollow profiles T6	≤5	255	215	8	6	85
	5<t≤15	250	200	8	6	85
EN AW-6082*[Al Si1 Mg Mn] - KSZTAŁTOWNIKI WYCISKANE/ EXTRUDED PROFILES						
T4	≤25	205	110	14	12	70
Profile otwarte T5 / Fiat profiles T5	≤5	270	230	8	6	90
Profile otwarte T6 ^c / Fiat profiles T6	≤5	290	250	8	6	95
	5<t≤25	310	260	10	8	95
Profile zamknięte T5 / Hollow profiles T5	≤5	270	230	8	6	90
Profile zamknięte T6 ^c / Hollow profiles T6	≤5	290	250	8	6	95
	5<t≤25	310	260	10	8	95

c Własności można uzyskać przez chłodzenie na wyjściu z prasy / Mechanical properties may be gained by cooling on the press exit

d Materiał przeznaczony do gięcia / Material for bending

e Jeżeli przekrój poprzeczny kształtownika zawiera różną grubość ścianki, należy z każdego z nich wybrać wartość najwyższą spośród tych wartości, które nie są niższe niż wartości określone w tabeli. W przypadku, gdy grubość ścianki jest różna, należy użyć wartości określonej dla najmniejszej grubości ścianki. / If the profile cross-section is comprised of different thicknesses which fall in more than one set of specified mechanical property values, the lowest specified values shall be considered as valid for the whole profile cross section.